

**IMAGE 1**

**SOLAR WALL LIGHTS**



# Introduction

01

FRONT COVER



02

CONTENTS



03

MAIN FEATURES



---

04

PRODUCT PARAMETER



05

MAIN FEATURES



06

PRODUCT ADVANTAGES



---

07

APPLICATIONS



08

DIMENTION FIGURE



09

IN DESIGN



---

10

PACKAGE DETAILS



11

END



## MAIN FEATURES

*Solar Wall Light Series*

# SOLAR WALL LIGHT



## *Solar Wall Led Light with Human sensor*

- ⊙ Aluminum alloy +PC , Never Fade
- ⊙ 53 Leds
- ⊙ White Led / Warm white to light your way
- ⊙ Human sensor , intellegient for light
- ⊙ Easy installation , IP65
- ⊙ Auto on/off day and night



## TECHNICAL SPECIFICATIONS

Technical Speficiaions	
Epistar SMD LED	500LM ,5W. Color Temperature : 6000-6500K
LED QTY	53pcs
Battery Type	3.7V 2200mAh, Li-ion,
Solar Panel	2.2W PET Laminated Plate
Charging method	Solar power
Solar charging time	6-8 hrs by bright sunshine
Lighting time	12hrs after full charged
Sensor	Light sensor
Lighting mode	When humen-detected , turn 100% bright , if no humen -deteced , it keeo dim 10% .
Material	ABS+PC
Product Size	L155 *W 122 *H61mm
IP level	65
Working Temperature	-25°C ~ 65°C
Warranty	1 year
Certificate	CE,ROHS ,FCC , ISO9001:2015
Installation height	2-3M
Package	Color box size:L166*w148*H70mm Weight:0.465KG Master carton size:525*355*343mm Weight: 13.8KG Qty:28PCS /CTN 1X20'GP: 10865pcs 1X40'GP: 22567pcs 1X40'HQ: 28418pcs

■ MAIN ADVANTAGE

\* SOLAR LIGHTS DESIGN

# S O L A R W A L L L I G H T S



l i m i t a t i o n w o o d g r a i n d e s i g n h i g h l i g h t s h i g h - e n d

## MAIN FEATURES

## Product Advantages

Light Control  
Aluminum Alloy Housing  
Easy Installation



TEMPERED GLASS HIGH-EFFICIENCY SOLAR PANEL TO CHARGE BATTERY



## MAIN ADVANTAGE

## Product Advantages

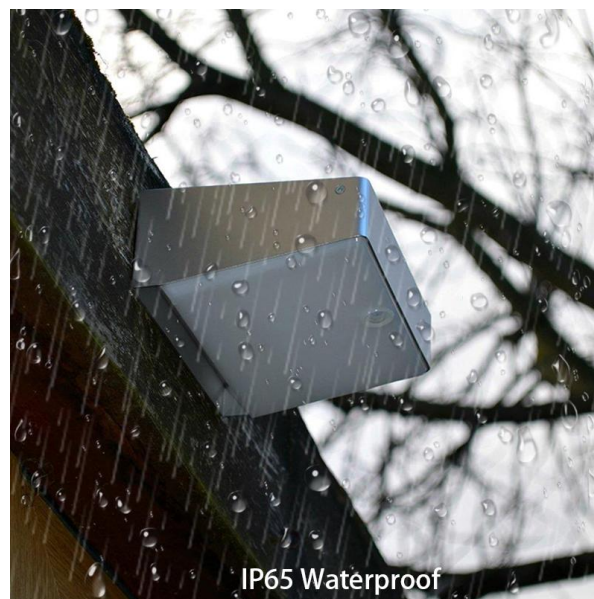
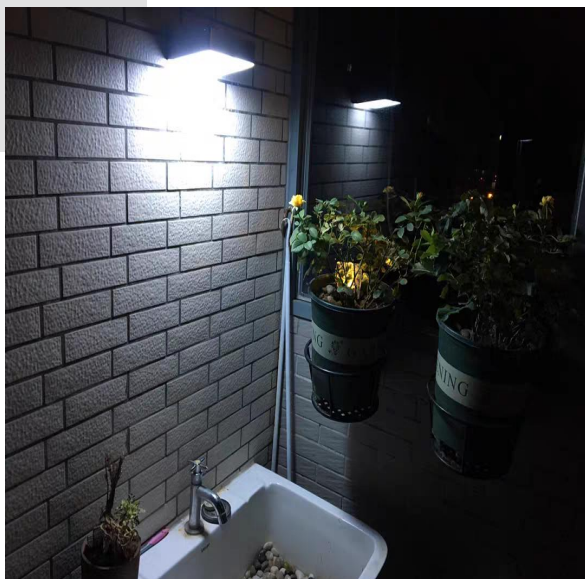

Very suitable using in Villa ,garden wall, courtyard wall,park wall,villa balcony

■ DIMENTION FIGURE

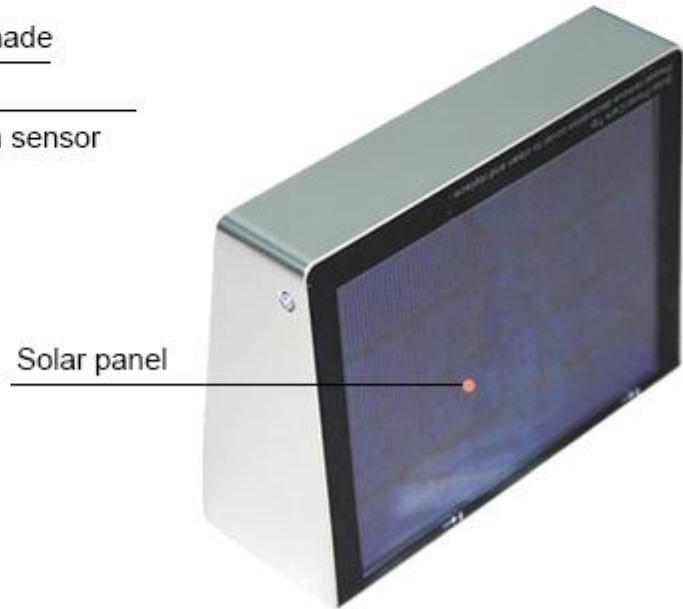
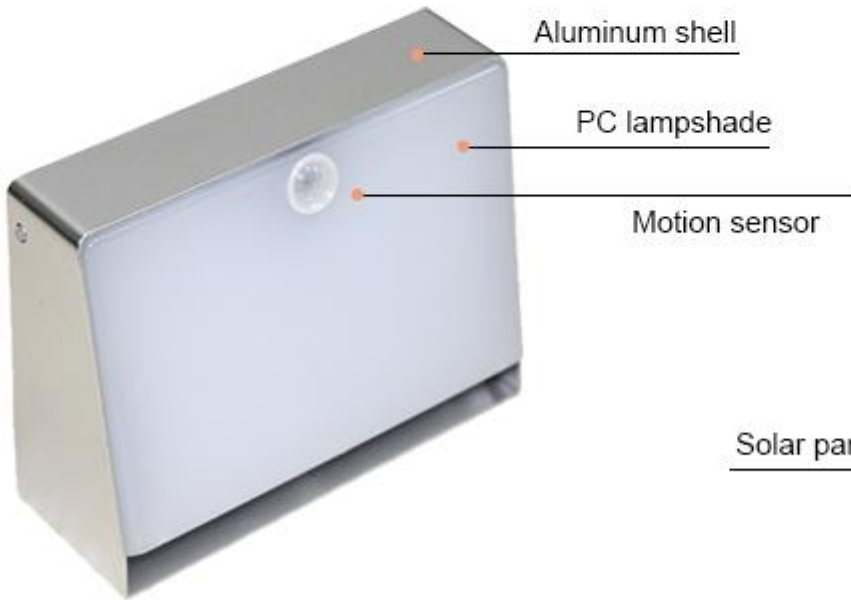
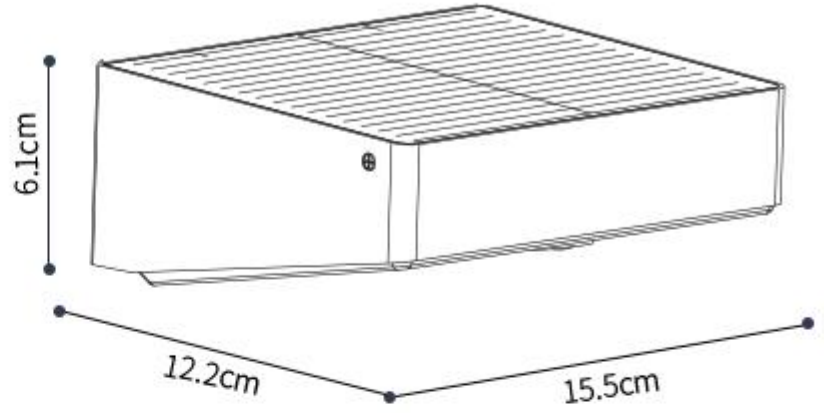



Product Design

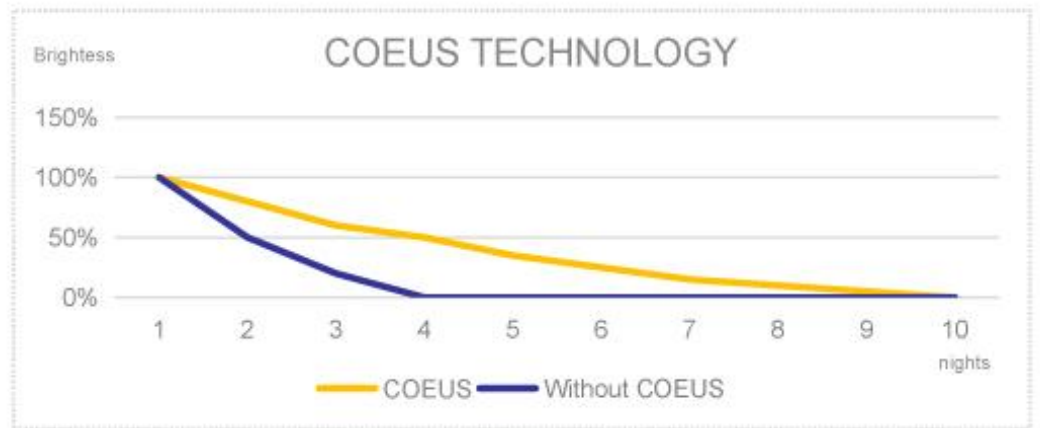
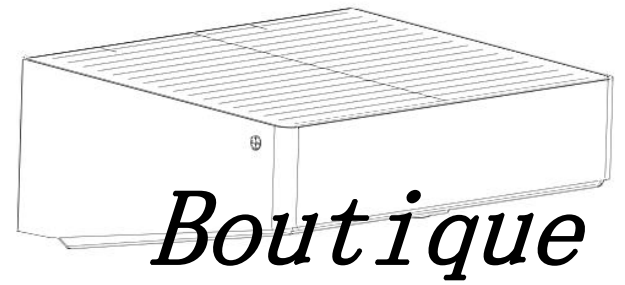

■ MAIN ADVANTAGE



Pearl cotton for protection

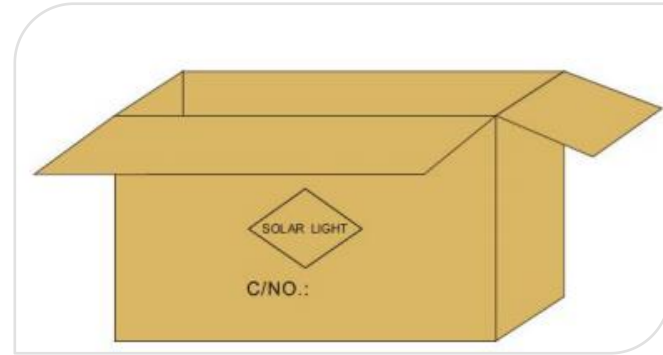

5-layer corrugated paper

Step1

Step2

	<b>SWL-03C</b>
Packing details	36pcs/ctn
Ctn Size	460*510*240mm
Gross weight	22kg

